

## SoIP- Connecting the VoIP and PSTN worlds

**Compact, High Performance and cost effective SS7 to IP Gateway.  
Signalling & Media Gateway in one box**

**Ideal for ISPs, pure-play VoIP operators or for adding VoIP connectivity to legacy switches**

SS7 interfaces are increasingly being used to connect to PSTN networks in situations where Q931 / ISDN PRI was used before. Whilst this gives operators a more powerful interface with higher level performance and reliability it can also mean expensive, heavily engineered signalling gateways are required.

**SoIP** gives you an easy to use, cost effective way of connecting VoIP based traffic to SS7 networks.

- 1 to 16 Signalling Link Pairs
- 1 to 32 E1 trunks
- SIP and H323
- 30 to 960 VoIP calls
- MTP Layer: ITU Q704, ISUP Layer: ETSI

Based on the field proven WTL signalling software installed on more than 100 operators. Support for many country / carrier variants.

## Applications

### SS7 Tunneling through IP Network

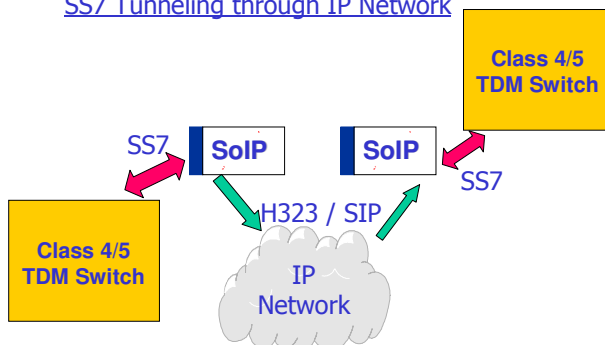

### Legacy Switch To VoIP Carriers

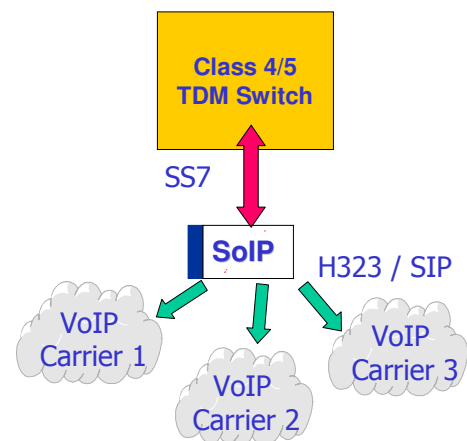

- Link legacy networks to VoIP carriers
- SS7 tunnelling through a VoIP network
- Create small SS7 PoPs
- Central signalling with distributed trunks
- Extend life of existing Class 4/5 switches
- Collect VoBB subscribers' traffic
- Connect Next-Gen Application Servers to TDM networks

## OSST – Optimised SS7 Transport

WTL have developed the highly efficient **OSST** to allow SS7 signalling to be carried through IP networks. This protocol encodes the full range of SS7 messages in a secure, compact way which has been optimised for IP transport. **OSST** then uses smart routing algorithms to decide which device in the network to send the SS7 message to. SS7 call control can thus be extended to remote SS7 trunks anywhere in the network or converted to be compatible with VoIP protocols.

## Carrier Grade Reliability

- **SoIP** has the SS7 support of a full blown Class 4 switch in a simple gateway format
- Full remote management
- Web based user interface
- Robust Solaris operating system
- Distributed MTP3 (DMTP3) allows redundant network design
- 1 to 16 SS7 signalling link pairs (upgradeable by software key)
- SS7 & VoIP trace facilities
- Compatible with wide range of IP equipment
- Scalability – SoIP starts with capacity for 30 simultaneous calls. Upgradeable to 960 calls and stackable to 61440 calls (2048 E1s).
- A private Ethernet port provides a html web browser interface with password protected access levels to allow configuration, administration, traffic monitoring and diagnosis.

Central SS7 Signalling Node With Remote Trunks

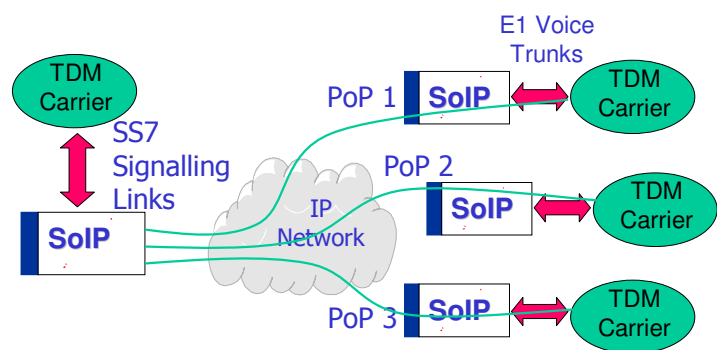

## Protect Your Investment in Existing Networks

Our goal is to give service and equipment providers the core technology needed for network convergence. Providers have made huge investments in services deployed on their legacy networks, and they have to be able to share services across legacy networks and with IP-based networks. **SoIP** from WTL allows multiple traffic types to co-exist in the same network.

## Specifications

- Operating System: Solaris 10
- 3 x SCSI RAID 5 + Pass through disk for emergency recovery
- Maximum number of SS7 links : 32
- Maximum number of SS7 trunks : 32
- SS7 Interfaces : T1/E1
- IP Interfaces : 2 x 10/100/1000 Base-T Ethernet
- Options: 2, 4, 8, 16, 24 or 32 trunks
- 60, 120, 240, 480, 720 or 960 VoIP calls
- Protocol Support: SIP, H323 Ver. 4
- Voice codecs: G723.1, GSM-FR, G726-32, G729, G711
- Destination Point Codes: 64
- Operational Point Codes: 4 National or international
- Maximum call set up: BHCC Rate (Busy Hour Call Completion) over 250,000 per SoIP Gateway
- Management options: Web UI, CLI
- Height : 4U      Depth : 755 mm
- Power: 1+1 redundant PSUs. Consumption: Max 800W